



MAKSIWA[®]

MK.300.1

MITER SAW 10" WITH LASER GUIDE AND DUAL SLIDING RAIL

INSTRUCTION MANUAL



ATTENTION: READ THIS MANUAL BEFORE USING THE PRODUCT.

PICTURE 1
(Illustrative Picture)

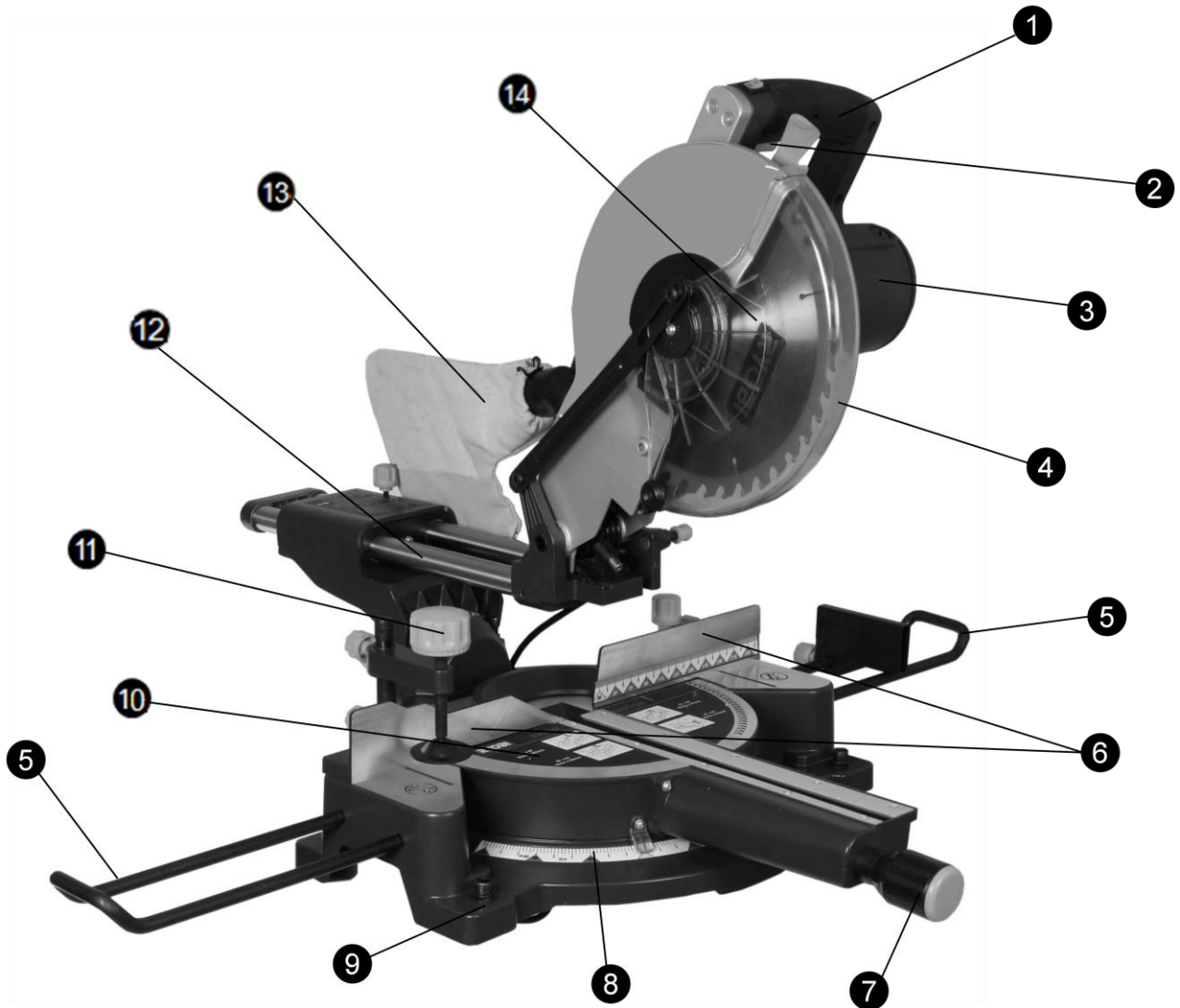

Picture 2
(Illustrative Picture)

1. Grip
2. Trigger switch
3. Engine Housing
4. Saw protector
5. Side Extenders
6. Side Guides
7. Square fastener button
8. Square Scale
9. Table Mounting Holes
10. Table
11. Fastener
12. Telescopic Guide
13. Dust Collector Bag
14. Cutting Disc

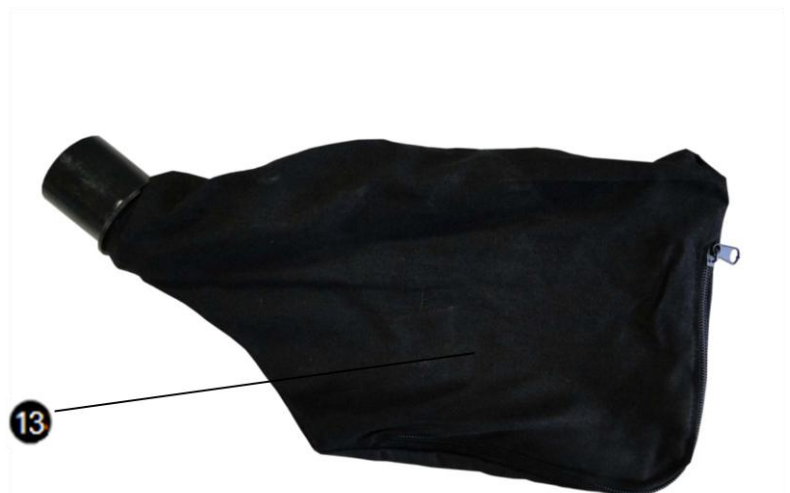

INSTRUCTION MANUAL

Important information you should know:

- Make cuts only with sharp blades. Discs that are not sharp do not cut properly and overload the engine.
- If the saw does not cut accurately, refer to the PROBLEM DETECTION table in this manual.



ALWAYS USE PROPER PROTECTIVE EQUIPMENT WHEN OPERATING THIS EQUIPMENT.

Important Safety Instructions



ATTENTION: When using power tools, always follow safety precautions to reduce the risk of fire, electric shock and personal injury, including the following:

READ ALL INSTRUCTIONS



Double Insulation

Double insulation tools are constructed with two separate layers of electrical insulation or double insulation thickness between you and the tool's electrical system. Tools built with this insulation system should not be grounded. As a result, your tool is equipped with a two-pin plug that allows the use of an electrical extension without the concern of maintaining a connection to the ground wire.

NOTE: Double insulation does not replace normal safety precautions when operating this tool. The isolation system is to add protection against personal accidents resulting from a possible failure in the electrical insulation of the tool.



CAUTION: WHEN MAINTAINING, REPLACE ONLY WITH IDENTICAL PARTS. Repair or replace damaged wires.

SECURITY INSTRUCTIONS FOR ALL TOOLS

- Remove the adjustment key. Make it a habit to ensure that the adjustment wrench is removed from the shaft before starting the tool.
- Keep the work surface clean. Disorganized areas and work surfaces invite accidents.

- Do not use the saw in hazardous environments. Do not use power tools in damp or wet or exposed to rain. Keep the work area well lit.

- Keep children away. All visitors must be kept at a safe distance from the work area.

- Make the workplace childproof by using padlocks, master keys or by removing the ignition key.

- Do not force the tool. It will do the job better and safer for the intended use. Use the correct tool.

- Do not force the tool when doing work for which it was not designed.

- Use suitable equipment. Do not wear loose clothing, gloves, chains, rings, bracelets or other accessories that could get caught in moving parts. Shoes with non-slip soles are recommended. Wear hair protection to secure it.

- Always wear safety glasses. Also wear a face mask.

- Secure the part to be worked. Use fasteners or vises when you are unable to secure the workpiece to the table and against the guide by hand or when your hand is dangerously close to the blade.

- Do not overreach. Keep your balance and your feet in a comfortable position at all times.

- Keep tools in order. Keep tools sharp and clean for better and safer performance. Follow instructions on lubricating and changing accessories.

- Disconnect tools before servicing or changing accessories, such as blades, tips, cutters, etc.

- Reduce the risk of unintentional starting. Make sure the switch is in the "OFF" position before connecting the wire to the plug,

- Use recommended accessories. Refer to the instruction manual to check the recommended accessories. Improper use of accessories can cause a risk of accident for people.

- Never step on the tool. A serious accident can occur if the tool is tilted or if the tool is touched accidentally.
- Check for damaged parts. Before continuing to use the tool, a guard or other part that is damaged must be carefully examined to determine its proper functioning and perform its function properly. Check the alignment of moving parts, broken parts, assembly and any other condition that may affect its operation. A protector or other part that is damaged must be repaired or replaced immediately. Do not use the tool if switch does not turn it on or off.
- Never leave a tool running unattended. Turn off the ignition key. The engines of these tools can emit sparks and explode flammable gases.
- Extension cables. Make sure your extension is in good condition. When using an extension cord, ensure that it is capable of transmitting the electrical current used by your product. An undersized cable will cause a voltage drop resulting in loss of power and overheating. The following table shows the correct size to be used depending on the cable diameter and the amperage rating. If in doubt, use a cable with higher voltage capacity. CAUTION: Do not use extension cords longer than 20 meters.

2-Way Wire		3-Way Wire	
Ø (mm ²)	Amperage	Ø (mm ²)	Amperage
0,5	9	0,5	8
1,0	13	1,0	12
1,5	16,5	1,5	15
2,5	23	2,5	20

Additional Safety Rules for Miter Saw:





CAUTION: FAILURE TO MEET THESE WARNINGS MAY RESULT IN PERSONAL ACCIDENT AND SERIOUS DAMAGE TO THE MACHINE.

- Protect the power supply line with at least a 15 amp fuse or a circuit breaker.
- Make sure that the blade is turning in the correct direction and that the teeth at the bottom of the blade are pointing towards the rear of the miter saw.
- Make sure the fasteners are secure before starting any operation.
- Make sure that all washers on the blade and fasteners are clean and that the sides preceded by flanges are against the blade. Tighten the axle screw securely.
- Keep the saw blade sharp.
- Keep the engine vents free of chips or dirt.
- Always use the blade guard.
- Keep your hands out of the way of the saw blade.
- Turn off the saw, disconnect the cable from the power outlet and wait until the blade stops completely before performing maintenance or adjustments to the tool. Support long pieces with a wood fixing device.
- Do not attempt to operate the saw at a voltage other than the designated voltage.
- Do not operate the saw unless all fasteners are secure.
- Do not use blades larger or smaller than recommended.
- Do not force anything against the fan to hold the motor shaft.
- Do not force the cut. Partial or total forced shutdown of the engine can cause serious damage. Allow the engine to reach full speed before starting to cut.
- Do not cut ferrous metals or any masonry material.
- Do not use abrasive bearings. Excessive heat and abrasive particles generated by these will damage the saw.
- Do not allow anyone to remain behind the saw.

- Do not apply lubricant to the blade when in operation.
- Do not put any hand on the blade area when the saw is connected to the power outlet.
- Do not use blades designed for less than 5,500 RPM.
- Do not cut small pieces without the aid of fasteners. Keep your hands away from the blade.
- Do not operate the saw without the guides.
- Do not perform any hands-free operation.
- Do not reach around or behind the blade.
- Do not put your hands within 6 inches of the saw blade.
- Do not put your hands under the saw unless it is disconnected and unplugged. The saw blade is exposed at the bottom of the saw.
- Do not move your hands from the saw or workpiece or raise your arms until the blade has stopped.
- Do not use the saw without the base or when it is wider than 10mm (3/8 ").
- Do not use lubricants or cleaning products (particularly sprays and aerosols) in the vicinity of the plastic protector. The polycarbonate material used in the protector is sensitive to certain chemicals.

 **ATTENTION:** Any dust created by sanding, cutting, grinding, drilling and other construction-related activities contain chemicals that can cause cancer, birth defects and other reproductive harm. Some examples of these products are: lead-based paints; brick silica crystal, cement and other masonry products; and arsenic and chromium from chemically treated wood.

 **CAUTION:** Do not connect the unit to an electrical outlet or power on until all instructions have been read and understood.

 Always tighten the adjustment clips before using the saw. Keep hands at 15 cm away from the saw blade. Never perform hands-free operations. Never cross your arms in front of the saw blade. Think, how can I avoid accidents!

Do not operate the saw unless the guards are in place. Never place your hands on the saw blade. Always wear safety glasses. Turn the tool off and wait for the disc to stop before restarting service, making adjustments or moving your hands.

Electrical Connection

Make sure your power supply matches the designation on the plate. A 10% decrease in voltage or more will cause loss of power and overheating. All MAKSIWA equipment is tested at the factory. If this tool does not work, check the power supply.

Familiarize yourself with the machine

Place the tool on a smooth, flat surface, such as a workbench or a strong, flat table. Check figures 1 and 2, and pay attention to the part descriptions to familiarize yourself with its different components. The next section will deal with the necessary adjustments for the tool to function properly, and will refer to the end that accompanies the illustrations. To do this, you must know these parts and you must know where they are. The name of each component is followed by a corresponding number in the illustration.

Specifications

Wattage	2000 W
Speed	4500 RPM
Net Weight	19,5 Kg
Saw Dimension	Ø254 x 16 x 2,8mm
Table Tilt	45° esquerda – 45° direita
Saw Tilt	0° a 45°
Max Cutting	90° x90°: 90 x 305mm
	90° x 45°: 90 x 215mm
	45° x 90°: 42 x 305mm
	45° x 45°: 42 x 215mm

Transport and Installation

For packaging reasons, the machine is not completely assembled.

If you notice any damage caused by transportation while opening the package, notify your supplier immediately. Do not operate the machine.



Dispose the packaging in a sustainable environmental way.

The miter saw is designed to operate indoors and must be placed on a firm, stable and level surface, as explained below:

Mounting on a workbench

The four legs of the saw have holes, as shown in figure 1, to facilitate the assembly of the table. Always assemble your saw by securing it firmly to prevent it from moving. To improve the transport of your tool, you can mount it on a piece of wood 13mm (1/2 ") or thicker, which can be fixed on the raised support to other work places.

NOTE: If you are going to fix your saw on a wooden plate, make sure that the screws will not go through the thickness of the wood. The wood must be parallel to the work table. When attaching the saw to any work surface, use vise or sergeants and fix it only by the feet where the screw holes are located. Attachment to any other part of the saw may interfere with the proper functioning of the equipment.



CAUTION: To prevent the saw from becoming move and cause lack of precision, make sure that the table where the saw is supported is not uneven. If the saw moves over the surface, place a support under the base until the saw settles firmly on the surface.

Installing a New Blade on the Equipment

IMPORTANT: Remove the miter saw from the socket.

Do not cut ferrous materials or masonry materials with this miter saw.

With the saw arm in the raised position, raise the blade guard as far as possible. Loosen (but do not remove) the guard console screw, until the guard console can be raised high enough to allow access to the blade screw. The blade guard will be held in the raised position by the console guard screw. Push the button

lock the shaft with one hand and use the blade wrench with the other to loosen (clockwise) the screw in the slot on the left side of the blade.

NEVER TIGHTEN THE AXLE LOCK PIN WHILE THE BLADE IS SPINNING. Be sure to hold the guard console down and securely secure the guard console screw when you finish installing the saw blade. Failure to do so will cause serious damage to the saw and possible personal injury.

NOTE: There are two different cut diameters on the inner plate, which have marked 25.4mm and 16mm. When installed, the outer diameter of the inner plate must correspond with the diameter of the saw blade. To install, place the blade and screw. Press and hold the shaft and tighten the screw in the opposite direction of the cranks with the key, then tighten again in the direction of the cranks (clockwise) with the metal guard screw.

NOTE: Only use the key that comes with the saw to install and remove the saw blade.

Saw assembly and adjustment: Switch off the saw before adjusting it.

Installing the square fastener button: Remove plastic bag square fastener button

Carefully screw on the arm located at the front of the saw.

Dust Bag Installation

Your saw comes with a dust bag. To install the bag, place the plastic opening in the dust extraction socket of the tool.

The saw can be used with a suction hose fitted to the machine's dust extraction support, or without any device.

MAKE THE ADJUSTMENTS HAVING THE SQUARE SAW DISCONNECTED FROM THE OUTLET.

NOTE: Your miter saw was precisely adjusted at the factory during manufacture. If it is necessary to readjust according to the transport and

handling or any other reason, follow the steps below to adjust your saw. Once these adjustments are made, they will remain accurate. Follow these instructions carefully to maintain the accuracy your saw is capable of.

Adjusting the Miter Scale

Place a square against the saw blade and guide (do not touch the tips of the blade teeth with the square. This will cause the fine adjustment to fail). Loosen the square fastener button and rotate the square arm until the square edge locks in the 0° position. Do not press the fastener button. If the saw blade is not exactly perpendicular to the guide, loosen the two screws that hold the square scale to the base and move the scale / square arm assembly to the right or left until the blade is perpendicular to the guide, as measured with square. Retighten the two screws. Do not pay attention to reading the square pointer at this point.

Protector Activation and Visibility

The saw blade guard is designed to lift automatically when the arm bends down and covers the disc when the arm rises.

The guard can be lifted manually when installing and removing the cutting disc or when necessary inspection of the saw.

NEVER LIFT THE CUTTING DISK PROTECTOR WHEN THE SAW IS IN OPERATION.

NOTE: Certain special cuts require you to lift the guard manually. To do this, simply place your right thumb on the top of the protector and slide it upwards to generate enough space for the piece to pass. Never remove the protector or prevent normal operation.

OPERATION

Connect the saw to any electrical outlet. Refer to the rating plate on your tool for the proper voltage. Make sure that cable is not on your way.

Switch:

Turn on the saw, press the trigger switch. To turn the tool off, release the switch. There is no mechanism to lock the switch in the on position.

Hand and Body Positioning

The proper positioning of the body and hands during the operation of the miter saw will make cutting easier, more accurate and safer. Never place your hands near the cutting area. Place your hands no closer than 15 cm from the blade. Hold the piece firmly against the table and the guide while cutting.

Keep your hands in position until the trigger has been released and the blade has come to a complete stop. **ALWAYS DO A TRIAL TEST (DISCONNECTED FROM THE POWER) BEFORE MAKING FINISHING CUTS SO YOU CAN CHECK THE BLADE PATH.**

Cutting with your saw

NOTE: Although your saw cuts wood and many other non-ferrous materials, we will limit ourselves to discussing only wood cutting. The same guidelines apply to other materials. **DO NOT CUT FERROUS MATERIALS (containing iron and steel) OR MASONRY MATERIALS WITH THIS SAW. DO NOT USE ABRASIVE BLADES.**

Cross sections

Cutting multiple pieces is not recommended, but can be done safely by ensuring that each piece is securely fastened against the table or the guide.

Cross-cutting is done by cutting the wood in the opposite direction to the fibers at any angle. A straight cross section is made with the miter arm in the 0° position. Set the square to zero, hold the wood firmly on the table against the guide. Turn the saw on by pulling the trigger. When the saw starts to pick up speed (after approximately 1 second), gently lower your arm to perform the

cut in the wood. Allow the blade to come to a complete stop before lifting the arm.

Transverse cuts are made with the square arm at any angle other than 0°. This angle is often 45° for making corners, but can be adjusted from 0° to 45° to the right or left. After selecting the desired angle, be sure to press the square fastener button. Make the cut as described above. **Beveled Cuts**

A bevel cut is a cross-section made with the saw blade not perpendicular to the wood. To adjust the chamfer, loosen the chamfer holder button and move the saw to the left as desired (it is not necessary to move the left side of the guide to allow opening). Once the chamfer is at the desired angle, press the fastener button firmly. The chamfer angles can be adjusted up to 45° to the left and the cut can be made with the square arm positioned between 0° and 45° to the right or left.

Cut Quality

The smoothness of any cut depends on a number of variables. Factors such as the type of material being cut, type of blade, blade sharpening and rate of cut contribute to the quality of the cut.

When smoother cuts are required for frames or other precision work, a sharp blade (60 - 80 carbon teeth) and a slower and more uniform rate of cut will produce desired results. Make sure that the material does not vibrate when cutting. Hold it firmly in place. Always wait for the blade to stop completely before raising your arm.

If small wood fibers continue to splash on the back of the piece, place a piece of masking tape on the wood where the cut will be made. Saw through the tape and carefully remove it when the cut is finished.

Setting the Workpiece

Unplug and unplug the saw.

If you are unable to secure the workpiece on the table and against the guide by hand (irregular shapes, etc.) or if your hand is less than 15 cm from the blade, a fastener or other fixation method should be used.

Other accessories such as spring clips, bar or "C" press may be suitable for certain sizes and shapes of material. Be careful in the selection and placement of these fasteners. Make sure to test with the tool off before making the cut.

Support for Long Pieces

Unplug and unplug the saw.

ALWAYS SUPPORT LONG PARTS.

Support long pieces using any convenient shape such as easels or similar structures to prevent the ends from falling.

CHECK THE MAKSIWA CATALOG AND FIND PRODUCTS FOR THIS FUNCTION. Cutting Frames, Boxes and Other Parts with Four Sides

To better understand how to make the items listed above, we suggest that you do some simple projects using wood scraps until you develop a certain skill with your saw.

Your saw is the perfect tool for cutting corners in frames. The adjustment of the square to chamfer the ends of two boards at an angle of 45° each produces a corner of 90°. For this joint, the square arm must be locked at 45°. The wood must be positioned with the wide, flat side against the table and the thin portion against the guide. The cut can also be done by cutting to the right and left with the wide surface against the guide.

The following table provides the appropriate angles for a number of shapes. The table assumes that all sides are the same length. For a format that is not shown in the table, use the following formula: 180° divided by the number of sides is equal to the angle of the chamfer or the square.

Examples

Number of sides	Chamfer or Square angle
4	45°
5	36°
6	30°
7	25,7°
8	22,5°
9	20°
10	18°

Cutting Compound Frames

A composite frame is a cut made using a square angle and a chamfer angle at the same time. This type of cut is used to make frames or boxes with slanted sides.

NOTE: if the cutting angle varies from cut to cut, check that the chamfer firing button and the square lock button are securely tightened. These buttons must be pressed after any changes to the chamfer or square have been made. The table shown will help to select the appropriate settings for chamfer and square for cutting common frame compounds.

Cutting of frames

In order to make a proper adjustment, the frames must be cut very precisely. The two flat surfaces of a frame have angles that, when joined, add exactly 90°. Most frames have an upper back angle (the side that goes against the flat part) of 52° and a lower back angle (the side that goes against the wall) of 38°.

In this case, doing preliminary tests with patchwork of frames is very important! Place the lower part (which goes against the wall) against the guide of the miter saw. Place the upper part (the one that goes against the flat part) against the saw table and the frame guide.

Instructions for cutting angular frames between the guide and the saw table, for all types of cuts:

1. Place the frame so that the bottom of this (the one that goes against the wall when affixed) is against the guide and the upper part of the frame against the saw table.

2. The miter plans at the rear of the frame must fit directly on the guide and the saw table.
3. Check the cuts so that they are flat, thus avoiding free spaces for their accuracy.

INTERNAL CORNER:

Left side

1. 45° left cut
2. Keep the left side of the cut

Right Side

1. 45° Right cut
2. Keep the right side of the cut

EXTERNAL CORNER:

Left side

3. 45° left cut
4. Save the left side of the cut

Right side

3. 45° straight cut
4. Keep the right side of the cut

SPECIAL CUTS

NEVER MAKE A CUT IF THE MATERIAL IS NOT SECURE ON THE TABLE AND GUIDE.

Aluminum Cutting

Use only specific discs for this cut. The instructions for aluminum, such as those used to make frames, rails etc., can be easily executed with the saw, using a disc for cutting non-ferrous metals. Place the material so that the thinnest part is exposed to the cut. When cutting aluminum, use wax lubricant. Apply the wax directly to the disc before cutting. Never apply wax when the disc is in motion. The wax available in most tool stores or in deposits of industrial suppliers offers adequate lubrication and prevents the frames from damaging the cutting disc. Make sure you have properly fixed the part. Due to their size, shape and surface finish, some parts may require

press, a mold or any other element to prevent movement during cutting.

Arched Material

When cutting a material that is arched, position it with the hollow facing the front of the equipment, and never facing the side guides. The incorrect position of the material may cause it to tighten the disc before finalizing the cut.

Cutting of Plastic Tubing and Other Circular Cross-Cutting Materials

The plastic tubing can be easily cut with your saw, just like cutting wood. For this, the material must fit firmly against the guide in order to prevent its movement, particularly when making angular cuts.

MAINTENANCE

1. All fixed parts of the saw are sealed. They are permanently lubricated and require no maintenance.
2. Clean and remove all dust and wood chips from the surroundings and under the base and rotary table periodically. Even if there are consoles to allow that waste to drain, there will be
3. the accumulation of dust.
4. The bushings are designed to provide several years of use.

Important: To maintain security and reliability

of the product, repairs, maintenance and adjustments should only be carried out by authorized technical assistance that will use identical parts for replacement. Frequent Troubleshooting Guide Be sure to follow the safety rules and instructions according to the table below.



CAUTION: The use of any accessory not recommended as a set for cutting channels, cutting frames or discs abrasives, can be dangerous.

TECHNICAL ASSISTANCE

For your greater safety, entrust repairs, maintenance and adjustments (including inspection and replacement) to the technical assistance recommended by MAKSIWA, which will always use genuine spare parts and accessories, reassembling your saw in the same way as the original.

The use of this tool for professional or industrial purposes is not recommended by MAKSIWA. Before using an extension cord, check for loose or exposed wires, damaged insulation and defective fittings. Repair or replace the extension if necessary.

Imported by Maksiwa USA Inc.
 4100 N Powerline Rd, Suite D3 Pompano Beach, FL 33073
 www.maksiwa.com
 754-205-6717

ISSUE	CAUSE	HOW TO FIX IT
Saw doesn't turn on	The saw is not connected to power	Connect the saw
	There is a burned fuse	Exchange the fuse
	The switch is open.	Close the switch
	The wire is damaged	Exchange the wire at a authorized workshop
	The coals have worn out.	Replace the coals at an authorized workshop.
Saw doesn't make satisfactory cuts	The disc is not sharp.	Exchange the disc
	The disc is mounted upside down.	Switch the position of the disc
	The disc is dirty.	Take off the disc and clean it
	Wrong disk for the job type.	Exchange the disc
	Part is poorly fixed.	Fix the part properly to your saw.
	The angle scale is not adjusted.	Check and adjust the scale.
	The disc is not aligned with the guide.	Check and adjust.
	The disc is not perpendicular to the table.	Check and adjust according to the instructions.
The disc does not reach working speed.	The moving work table.	Fit the workpiece to the guide.
	Extension cable too thin or too wide.	Replace with a suitable extension.
	Dirt preventing movement of the disc.	Remove the disc and clean it.
The machine vibrates excessively.	The electric current is too low (oscillating).	Contact your power supplier
	Saw incorrectly attached to the table.	Check the assembly instructions.
	Table or bench with uneven surface r.	Place the saw on a suitable surface.
The material damages the disc.	The saw blade is damaged.	Replace the disc.
	It is cutting arched material.	Place the part according to the instructions.
	Material in disagreement with the instructed.	See instructions for materials.